



DP1211 – C868/C915/C950

868, 915 and 950 MHz Drop-In RF Transceiver Modules

Combine Small Form Factor with High Performance

GENERAL DESCRIPTION

The DP1211 is a low cost transceiver operating in the frequency ranges from 863-870, 902- 928 MHz and 950-960 MHz. The DP1211 is optimized for very low power consumption (3mA in receiver mode). It incorporates a baseband modem with data rates up to 100 kb/s. Data handling features include a sixty-four byte FIFO, packet handling, automatic CRC generation and data whitening. All major RF communication parameters are programmable and most of them may be dynamically set. It complies with European (ETSI EN 300-220 V2.1.1) and North American (FCC part 15) regulatory standards.

KEY PRODUCT FEATURES

- Low Rx power consumption: 3mA
- Low Tx power consumption: 25 mA @ +10 dBm
- Good reception sensitivity: down to -107 dBm at 25 kb/s in FSK, -113 dBm at 2kb/s in OOK
- Programmable RF output power: up to +12.5 dBm in 8 steps
- Packet handling feature with data whitening and automatic CRC generation
- RSSI (Received Signal Strength Indicator) range from noise floor to 0 dBm
- Bit rates up to 100 kb/s, NRZ coding
- On-chip frequency synthesizer
- FSK and OOK modulation
- Incoming sync word recognition
- Built-in Bit-Synchronizer for incoming data and clock synchronization and recovery

APPLICATIONS

- Wireless alarm and security systems
- Wireless sensor networks
- Automated Meter Reading
- Home and building automation
- Industrial monitoring and control

DEVICE OPTIONS

Part	Frequency band	Pin Package
DP1211C868	868 - 870MHz	Board
DP1211C915	902 - 928MHz	Board
DP1211C950	950 - 960MHz	Board

Table of Contents

1. PIN DESCRIPTION	3
2. ELECTRICAL CHARACTERISTICS	4
2.1. ABSOLUTE MAXIMUM OPERATING RANGES	4
2.2. SPECIFICATIONS	5
3. FUNCTIONAL DESCRIPTION	6
4. DATA OPERATION MODES.....	7
5. SERIAL CONTROL INTERFACE.....	8
6. OPERATING MODES.....	9
6.1. Switching Times from Sleep to Receive Mode	9

1. PIN DESCRIPTION

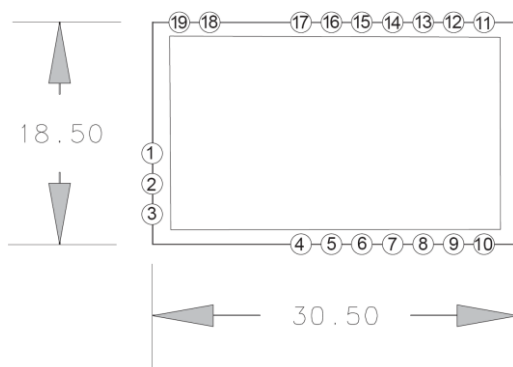

PIN	NAME	I/O	DESCRIPTION
1	GND		Ground
2	RF_IN_OUT	IN/OUT	RF Input / Output terminal
3	GND		Ground
4	GND		Ground
5	GND		Ground
6	VDD		Supply Voltage
7	NSS_CONFIG	IN	SPI SELECT CONFIG
8	NSS_DATA	IN	SPI SELECT DATA / DATAIN
9	IRQ0	OUT	Interrupt (PATTERN//FIFOEMPTY)
10	GND		Ground
11	GND		Ground
12	IRQ1	OUT	Interrupt(DCLK/FIFOFULL)
13	DATA	IN/OUT	Data
14	CLKOUT	OUT	Output clock at reference frequency divided by 2, 4, 8, 16, 32
15	MISO	OUT	SPI Master Input Slave Output
16	MOSI	IN	SPI Master Output Slave Input
17	SCK	IN	SPI CLOCK
18	PLL_Lock	OUT	PLL lock detection Output
19	N/C		

WIRELESS PRODUCTS

2. ELECTRICAL CHARACTERISTICS

2.1. ABSOLUTE MAXIMUM OPERATING RANGES

Description	Min	Max	Unit
Supply voltage	2.1	3.6	V
Operating temperature	-40	+85	°C
Storage temperature	-55	125	°C
Soldering temperature (max 15 sec)		260	°C



CAUTION: ESD sensitive device.
Precaution should be taken when handling the device in order to prevent permanent damage



Life Support Policy and Use in Safety Critical Applications

SEMTECH PRODUCTS ARE NOT DESIGNED, INTENDED, AUTHORIZED OR WARRANTED TO BE SUITABLE FOR USE IN LIFE-SUPPORT APPLICATIONS, DEVICES OR SYSTEMS OR OTHER CRITICAL APPLICATIONS. INCLUSION OF SEMTECH PRODUCTS IN SUCH APPLICATIONS IS UNDERSTOOD TO BE UNDERTAKEN SOLELY AT THE CUSTOMER'S OWN RISK.

WIRELESS PRODUCTS

2.2. SPECIFICATIONS

Conditions: Temp = 25 °C, VDD = 3.3 V, crystal frequency = 12.8 MHz, carrier frequency = 869 or 915 MHz, modulation FSK, data rate = 25 kb/s, Fdev = 50 kHz, fc = 100 kHz, unless otherwise specified.

Symbol	Parameter	Conditions	Min	Typ	Max	Units
FR	Synthesizer Frequency Range	DP1211-C868	863	-	870	MHz
		DP1211-C915	902	-	928	MHz
		DP1211-C950	950	-	960	MHz

IDDSL	Sleep mode supply current		-	0.1	2	µA
IDDST	Standby mode supply current	12.8 MHz running	-	65	80	µA
IDDFS	Supply current in FS mode	Frequency synthesizer running		1.3	1.7	mA
IDDR	RX mode supply current			3	3.5	mA
IDDT	TX mode supply current	PRF = 1 dBm		16	21	mA
		PRF = 10 dBm		25	30	mA

RFS_F	RF Sensitivity (FSK)*	BR=25 kbps / 869 MHz		-107	-	dBm
		BR=25 kbps / 915 MHz		-105	-	dBm
RFS_O	RF Sensitivity (OOK)*	BR=2 kbps / 869 MHz		-113	-	dBm
		BR=2 kbps / 915 MHz		-111	-	dBm

FDA	Frequency Deviation	Programmable	33	50	200	kHz
BR_F	Bit rate (FSK)	Programmable	1.56	-	200	Kb/s
BR_O	Bit rate (OOK)		1.56	-	32	Kb/s

RFOP	RF output power, programmable with 8 steps of typ. 3dB	Programmable.	-8,5		+12,5	dBm
------	--	---------------	------	--	-------	-----

TS_TR	Transmitter wake-up time	From FS to Tx ready.	-	120	500	µs
TS_RE	Receiver wake up time	From FS to Rx ready.	-	280	500	µs
TS_OSC	Quartz oscillator wake up time	From sleep mode.	-	1.5	5	ms

XTAL	Quartz oscillator frequency		9	12.8	15	MHz
------	-----------------------------	--	---	------	----	-----

*All sensitivities are measured receiving a PN15 sequence, for a BER of 0.1%

3. FUNCTIONAL DESCRIPTION

The DP1211 is a cost effective high performance radio transceiver module designed for the wireless transmission of digital information.

The module is based on the RF transceiver circuit from Semtech, the SX1211. For more information on the SX1211, please refer to the datasheet, available from the Semtech website:

<http://www.semtech.com> .

As illustrated below, illustrates the SX1211 data processing circuit. Its role is to interface the data to/from the modulator/demodulator and the μ C access points (SPI, IRQ and DATA pins). It also controls all the configuration registers.

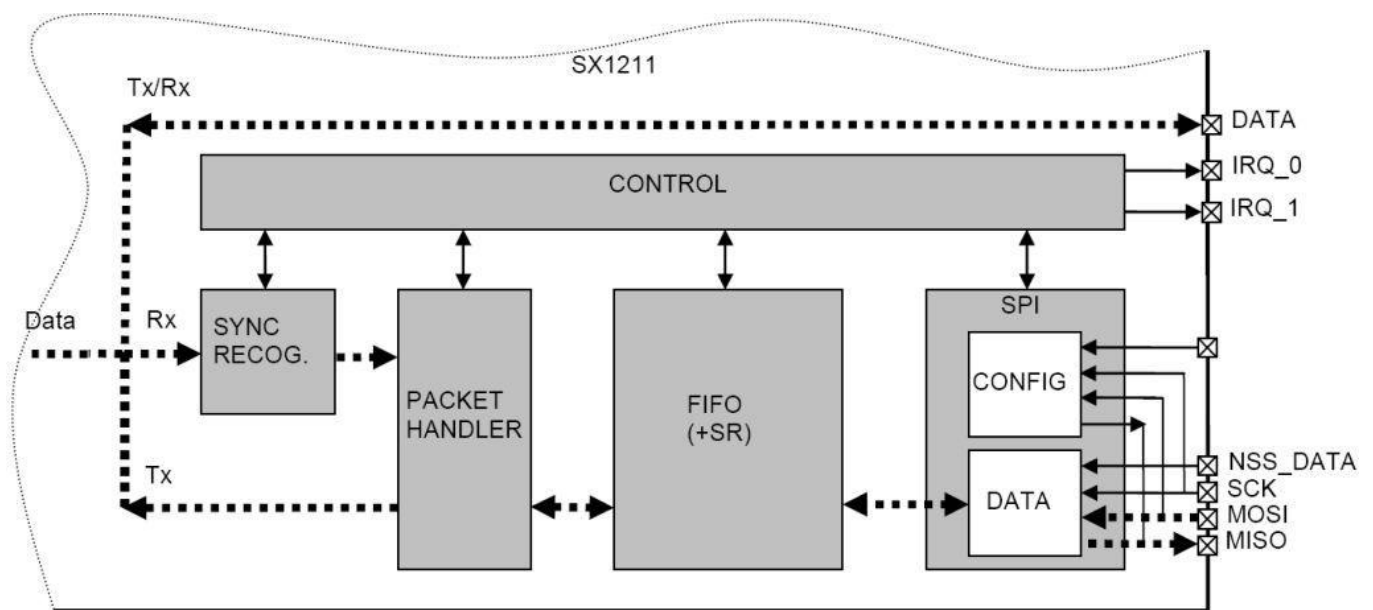

WIRELESS PRODUCTS

4. DATA OPERATION MODES

The DP1211 has three different data operation modes selectable by the user:

Continuous mode: each bit transmitted or received is accessed in real time at the DATA pin. This mode may be used if adequate external signal processing is available.

Buffered mode: each byte transmitted or received is stored in a FIFO and accessed via the SPI bus. μ C processing overhead is hence significantly reduced compared to Continuous mode operation. The packet length is unlimited.

Packet mode (recommended): user only provides/retrieves payload bytes to/from the FIFO. The packet is automatically built with preamble, Sync word, and optional CRC, DC free encoding and the reverse operation is performed in reception. The μ C processing overhead is hence reduced further compared to Buffered mode. The payload length is limited to 64 bytes (maximum FIFO size).

IRQParam_RX_stby_IRQ_0	MCPParam_Data_Mode_0	IRQ_0_Rx	IRQ_0_Stby
00	00	Sync	In Continuous mode, no interrupt is available in Stby mode
01	00	RSSI	
10	00	Sync	
11	00	Sync	
00	01	-	-
01	01	Write_byte	-
10	01	/Fifoempty	/Fifoempty
11	01	Sync	-
00	1x	Payload_ready	-
01	1x	Write_byte	-
10	1x	/Fifoempty	/Fifoempty
11	1x	Sync or Adrs_match*	-

*The latter if Address filtering is enabled

Table 1: IRQ_0 interrupt sources in receive mode.

IRQParam_RX_stby_IRQ_1	MCPParam_Data_Mode_0	IRQ_1_Rx	IRQ_1_Stby
00	00	DCLK	In Continuous mode, no interrupt is available in Stby mode
01	00		
10	00		
11	00		
00	01	-	-
01	01	Fifofull	Fifofull
10	01	RSSI	-
11	01	Fifo_threshold	Fifo_threshold
00	1x	CRC_OK	-
01	1x	Fifofull	Fifofull
10	1x	RSSI	-
11	1x	Fifo_threshold	Fifo_threshold

Table 2: IRQ_1 interrupt sources in receive mode.

For more information about the data operation modes, please refer to the SX1211 datasheet chapter: *Description* You can find this at <http://www.semtech.com> .

5. SERIAL CONTROL INTERFACE

SPI Config: used in all data operation modes to read and write the configuration registers which control all the Parameters of the chip (operating mode, bit rate, etc...)

SPI Data: used in Buffered and Packet mode to write and read data bytes to and from the FIFO. (FIFO Interrupts can be used to manage the FIFO content.)

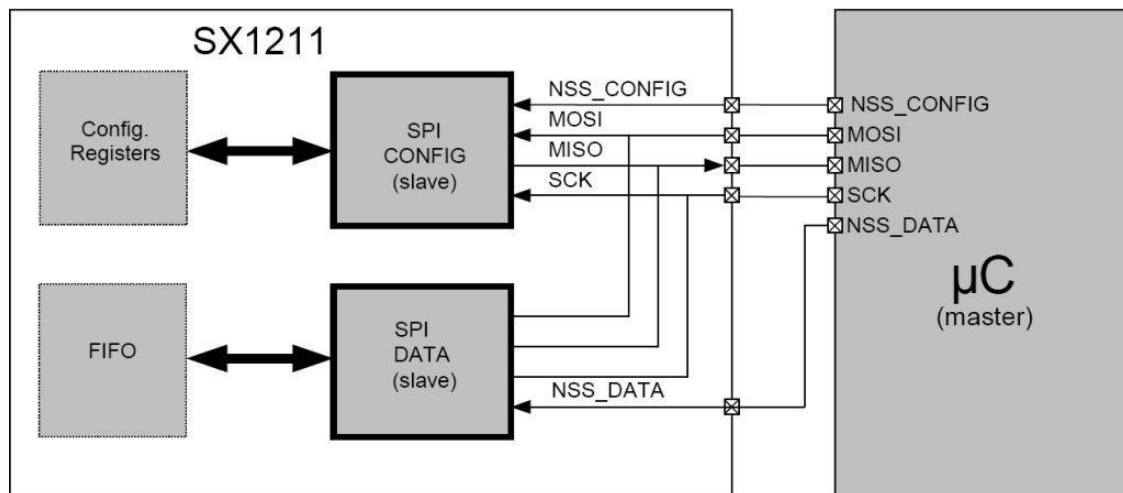

SPI Interface Overview and μ C Connections

For more information about the serial interface, please refer to the SX1211 datasheet chapter: Serial Interface definition and principle of operation. You can find this at <http://www.semtech.com>.

6. OPERATING MODES

This section summarizes the settings for each operating mode of the DP1211, and explains the Switching Time & Current consumption to RX Mode.

Mode	MCPParam_Chip_mode	Status
Sleep	000	-
Standby	001	Crystal oscillator running
FS	010	Frequency synthesizer
Receive	011	Ready to Receive
Transmit	100	Ready to Transmit

6.1. Switching Times from Sleep to Receive Mode

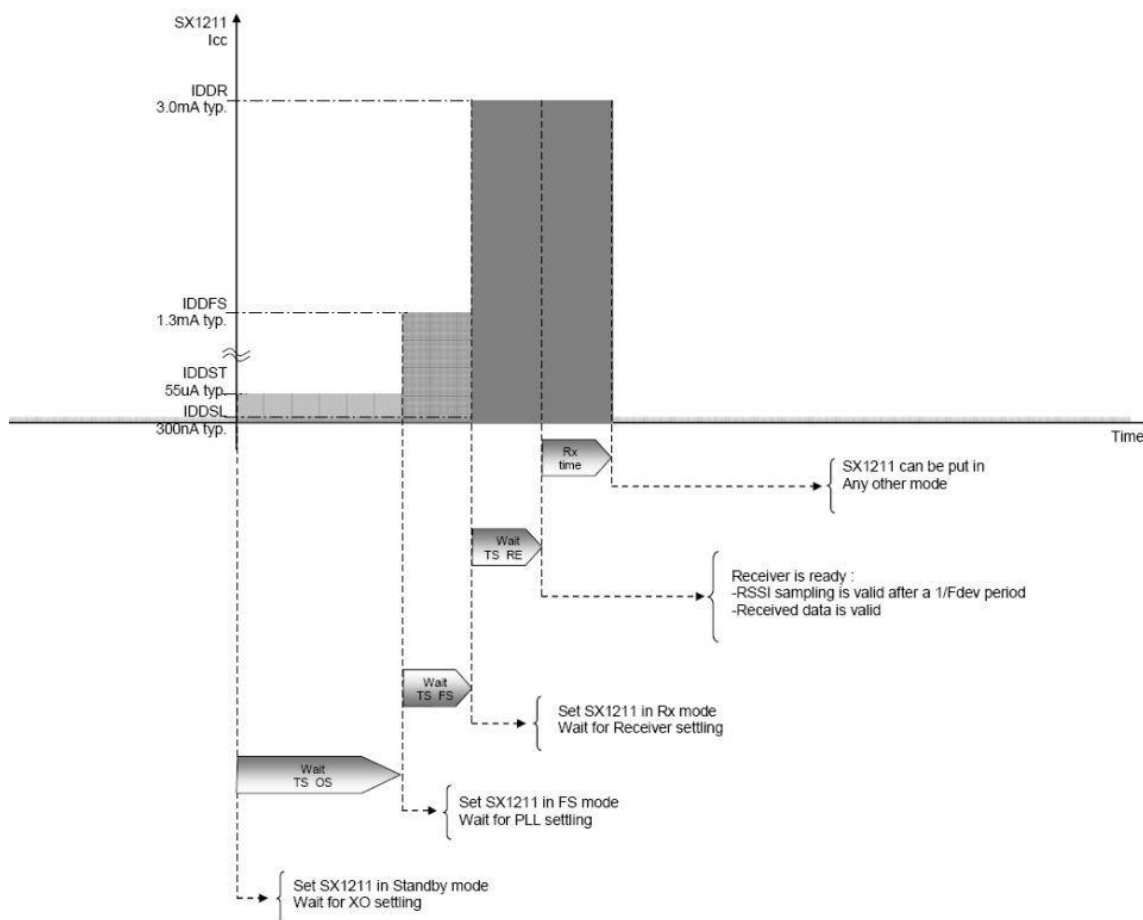

For more information about the modes of operation, please refer to the SX1211 Datasheet on the Semtech website <http://www.semtech.com>.

7. MECHANICAL DIMENSIONS

The following diagram shows the physical footprint and dimensions of the DP1211 drop-in module, which should be implemented on the mother board.

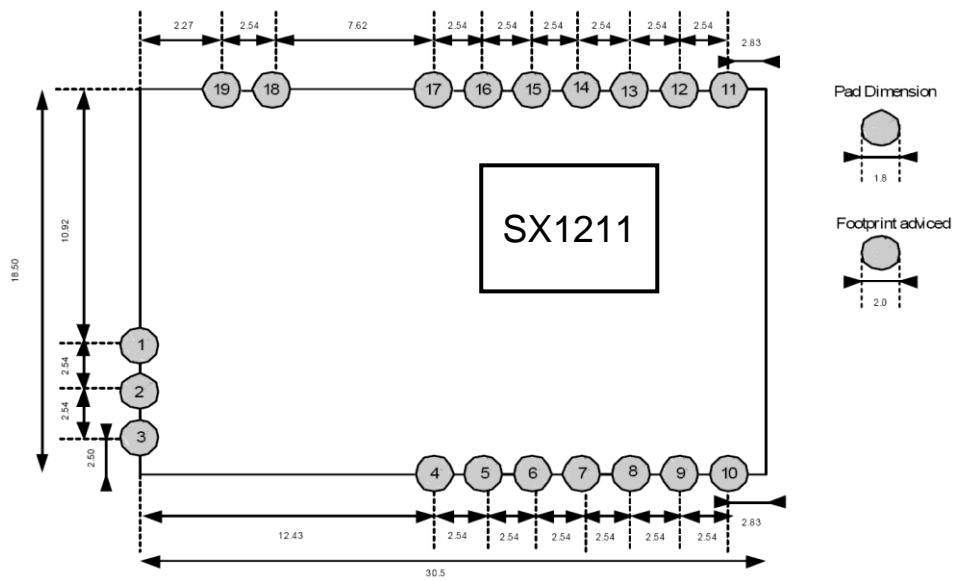

WIRELESS PRODUCTS

© Anylink 2007

All rights reserved. Reproduction in whole or in part is prohibited without the prior written consent of the copyright owner. The information presented in this document does not form part of any quotation or contract, is believed to be accurate and reliable and may be changed without notice. No liability will be accepted by the publisher for any consequence of its use. Publication thereof does not convey nor imply any license under patent or other industrial or intellectual property rights. Anylink assumes no responsibility or liability whatsoever for any failure or unexpected operation resulting from misuse, neglect improper installation, repair or improper handling or unusual physical or electrical stress including, but not limited to, exposure to parameters beyond the specified maximum ratings or operation outside the specified range.

ANYLINK PRODUCTS ARE NOT DESIGNED, INTENDED, AUTHORIZED OR WARRANTED TO BE SUITABLE FOR USE IN LIFE-SUPPORT APPLICATIONS, DEVICES OR SYSTEMS OR OTHER CRITICAL APPLICATIONS. INCLUSION OF ANYLINK PRODUCTS IN SUCH APPLICATIONS IS UNDERSTOOD TO BE UNDERTAKEN SOLELY AT THE CUSTOMER'S OWN RISK. Should a customer purchase or use Anylink products for any such unauthorized application, the customer shall indemnify and hold Anylink and its officers, employees, subsidiaries, affiliates, and distributors harmless against all claims, costs damages and attorney fees which could arise.

Version	Create Date:	Creator	Changes
0.1	21.09.10	Hermann	Create new Datasheet

Contact Information:

Anylink Systems AG

 Marie Curie Str. 2
 85055 Ingolstadt
 Germany

 Phone (+49) 841-9014-451
 Fax: (+49) 841-9014-452